

REV.	DESCRIPTION/ECD NO.	DATE
B	CORRECTED SHAFT LENGTH DIMENSION	10/13/00
B	PILOTT FLANGE HGT.	03/02/01

J1
MATING CONNECTOR:
MOLEX MINI1FT-16
39-01-3163

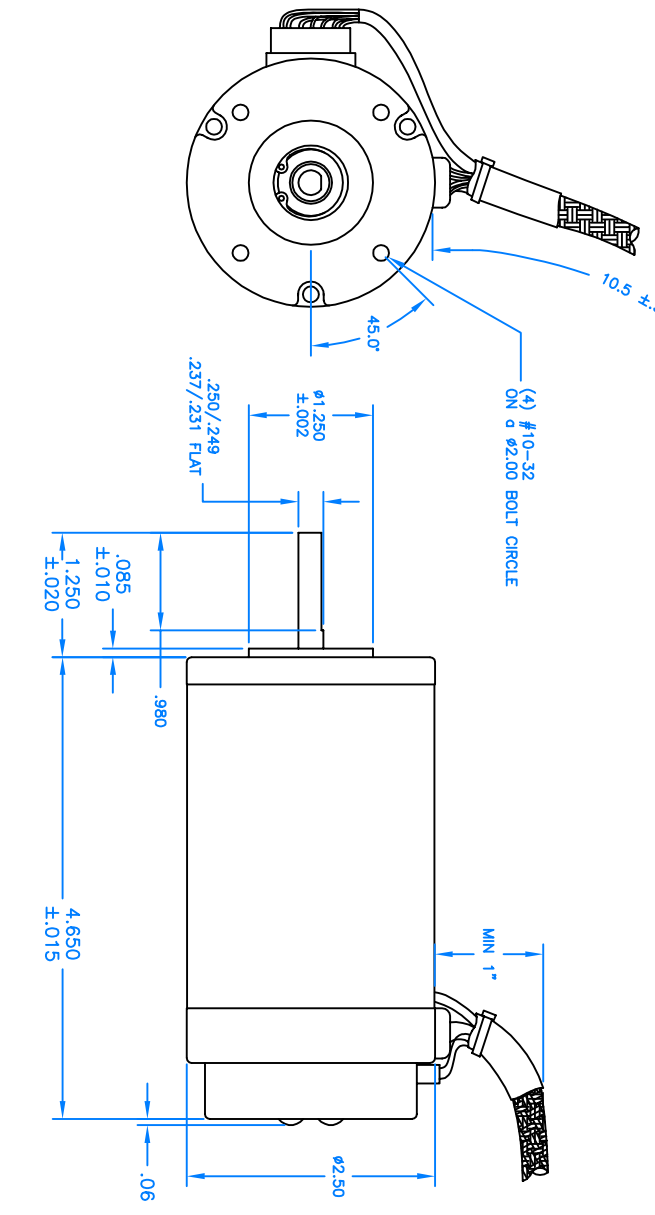

M-2348-XX

J1 Assignments
1 CHASSIS
2 +5V
3 COMM-R
4 COMM-S
5 COMM-T
6 GND
7 GND
8 NC
9 ϕ -R
10 ϕ -S
11 ϕ -T
12 +5V
13 ENC-I
14 ENC-B
15 ENC-A
16 GND

ALL DIMENSIONS IN INCHES

MATERIAL FINISH N/A TOLERANCES UNLESS OTHERWISE SPECIFIED ARE ANGULAR $\pm 1^\circ$ LINEAR $\pm .020$ SCALE NONE DRAWN BY DATE 12/15/98 FILENAME M-2348 ALL.DWG DWGNO. 2348 REV. C

BRUSHLESS MOTOR, NEMA 23,
M-2348, 300 OZ-IN

Teknic, Inc.
1150-E PITTSFORD-VICTOR ROAD
PITTSFORD, NY 14534