

REV.	DESCRIPTION/ECD NO.	DATE
B	CORRECTED SHAFT LENGTH DIMENSION	10/13/00
B	PILOTT FLANGE HGT.	03/02/01

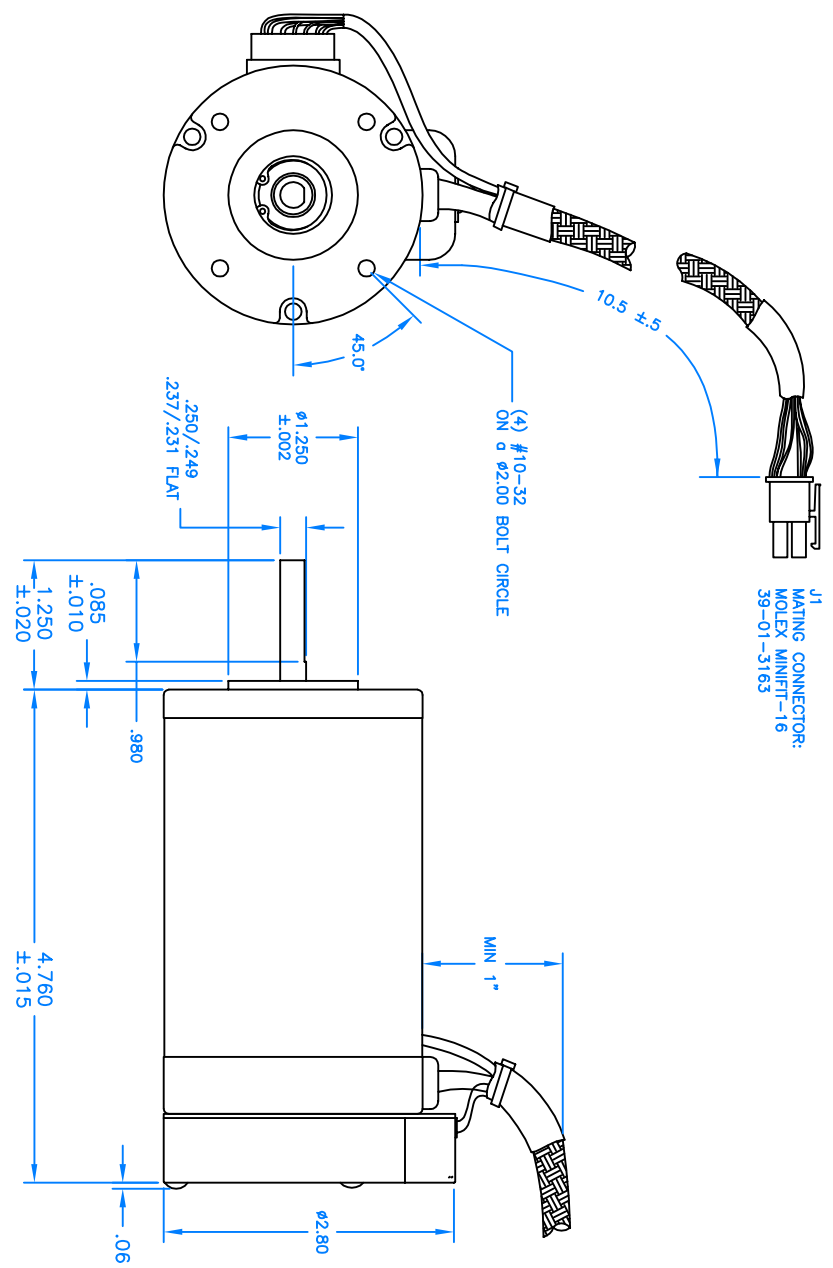

J1 MATING CONNECTOR:
MOLEX MINI1FT-16
39-01-3163

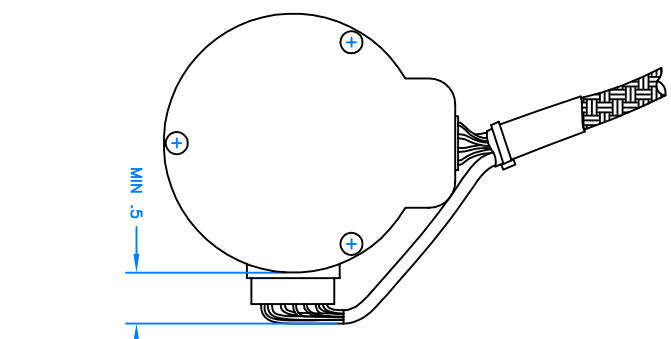

J1 Assignments
PIN SIGNAL
1 CHASSIS
2 +5V
3 COMM-R
4 COMM-S
5 COMM-T
6 GND
7 GND
8 NC
9 φ-R
10 φ-S
11 φ-T
12 +5V
13 ENC-I
14 ENC-B
15 ENC-A
16 GND

M-2348-XH

BRUSHLESS MOTOR, NEMA 23,
M-2348, 300 OZ-IN

 Teknic, Inc.
1150-E PITTSFORD-VICTOR ROAD
PITTSFORD, NY 14534

ALL DIMENSIONS IN INCHES	MATERIAL	FINISH	TOLERANCES UNLESS OTHERWISE SPECIFIED ARE:	SCALE	DRAWN BY	DATE	FILENAME	DWGNO.	REV.
		N/A	ANGULAR ± 1° LINEAR ± .020	NONE	DIRL	12/15/98	M-2348 ALL.DWG	2348H	C