

REV.	DESCRIPTION/ECD NO.	DATE
B	CORRECTED SHAFT LENGTH DIMENSION	10/13/00
C	ADJUSTED BODY LENGTH	03/02/01

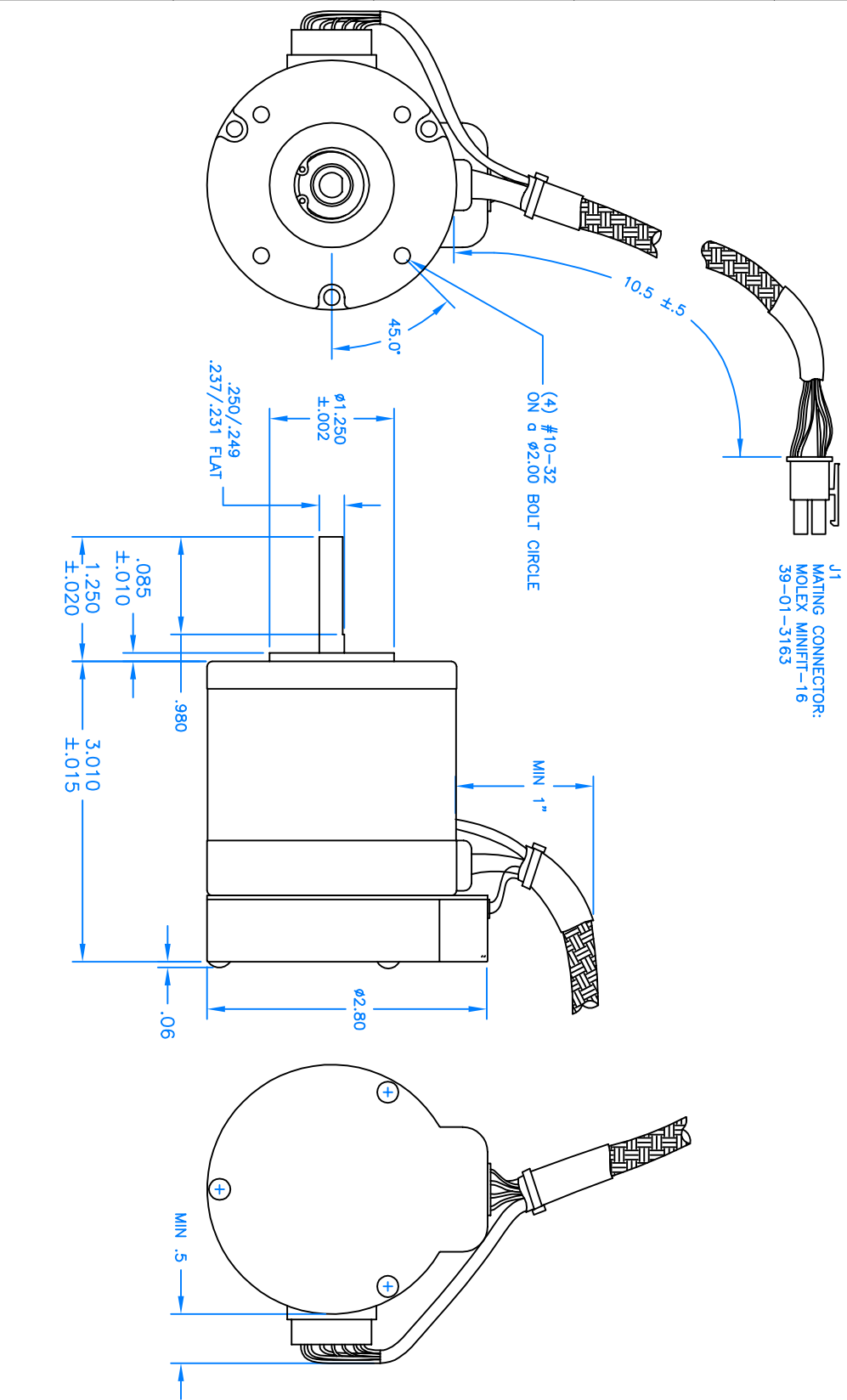

J1 Assignments	PIN	SIGNAL
1	CHASSIS	
2	+5V	
3	COMM-R	
4	COMM-S	
5	COMM-T	
6	GND	
7	GND	
8	NC	
9	$\phi-R$	
10	$\phi-S$	
11	$\phi-T$	
12	+5V	
13	ENC-I	
14	ENC-B	
15	ENC-A	
16	GND	

M-2330-XH

BRUSHLESS MOTOR, NEMA 23,
M-2330, 160 DZ-IN

Teknic, Inc.
1150-E PITTSFORD-VICTOR ROAD
PITTSFORD, NY 14534

ALL DIMENSIONS IN INCHES	MATERIAL	FINISH	TOLERANCES UNLESS OTHERWISE SPECIFIED ARE:	SCALE	DRAWN BY	DATE	FILENAME	DWGNO.	REV.
		N/A	ANGULAR $\pm 1^\circ$ LINEAR $\pm .020$	NONE	DRL	12/15/98	M-2330	2330H	C