

REV.	DESCRIPTION/ECD NO.	DATE
B	CORRECTED SHAFT LENGTH DIMENSION	10/13/00
C	ADJUSTED BDDY LENGTH	03/02/01

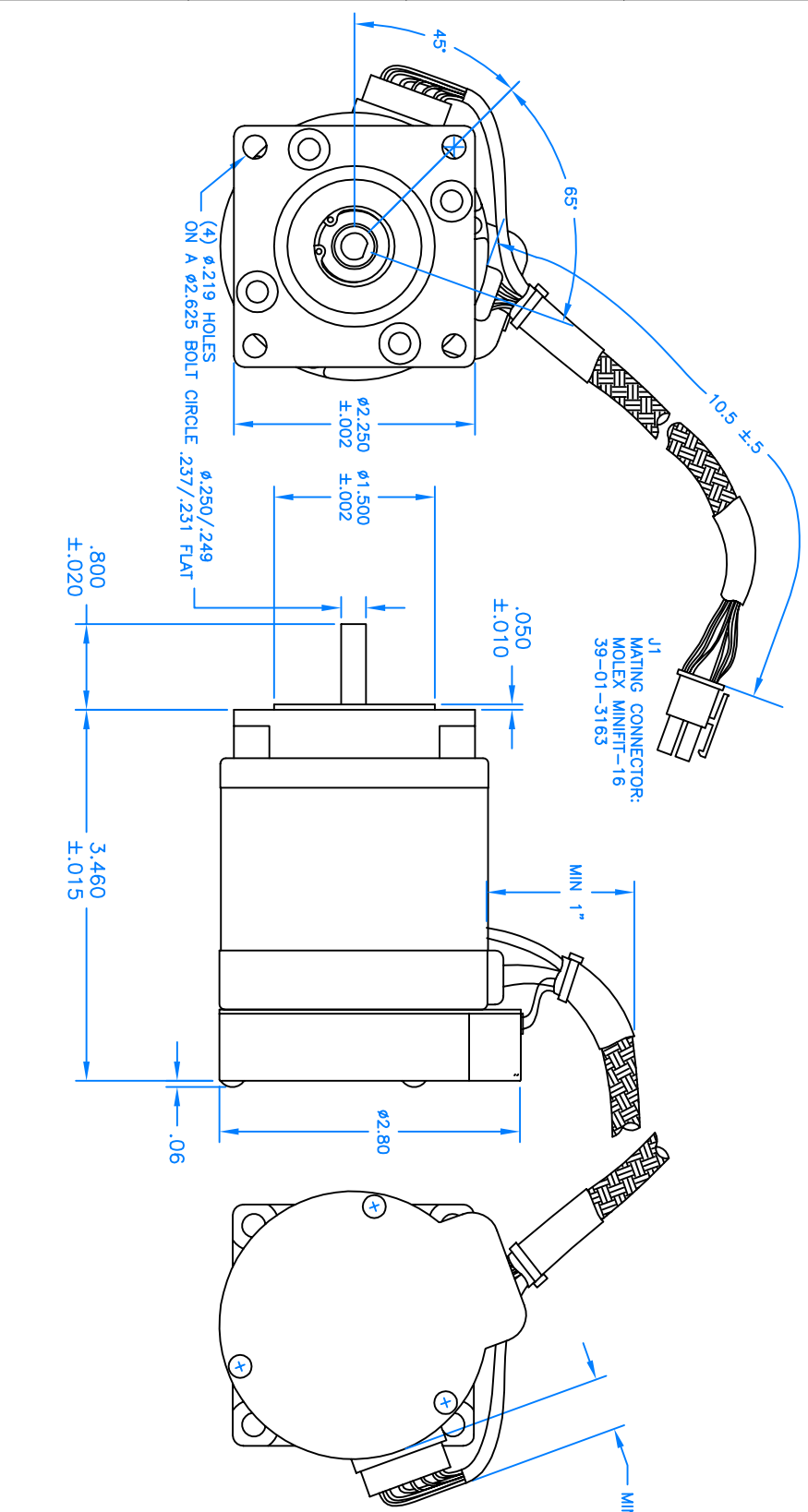

J1 Assignments
1 CHASSIS SIGNAL
2 +5V
3 COMM-R
4 COMM-S
5 COMM-T
6 GND
7 GND
8 NC
9 Ø-R
10 Ø-S
11 Ø-T
12 +5V
13 ENC-I
14 ENC-B
15 ENC-A
16 GND

M-2330-FH

BRUSHLESS MOTOR, NEMA 23,
M-2330, 160 OZ-IN, FLANGE

Teknic, Inc.
1150-E PITTSFORD-VICTOR ROAD
PITTSFORD, NY 14534

ALL DIMENSIONS IN INCHES	MATERIAL	FINISH	TOLERANCES UNLESS OTHERWISE SPECIFIED ARE:	SCALE	DRAWN BY	DATE	FILENAME	DWGNO.	REV.
	MATERIAL	N/A	ANGULAR ± 1° LINEAR ± .020	NONE	DRL	12/15/98	M-2330	2330FH	C