

INSTALLATION AND USE GUIDE

AMAZON INTELLIGENT POWER CENTER (IPC)

FOR MODELS IPC-25-XX AND IPC-75-XX
DOES NOT COVER MODELS IPC-3 AND IPC-5

VERSION 1.82 / MARCH 4, 2014

THIS PAGE INTENTIONALLY LEFT BLANK

INTRODUCTION	1
What is the Amazon Intelligent Power Center?.....	1
The bottom line	1
SAFETY	2
General Precautionary Statement.....	2
Symbols Used in this Manual	2
SYSTEM OVERVIEW (MODELS LX AND FX)	3
Amazon IPC Operation	3
MECHANICAL INSTALLATION	5
Mounting Orientation and Clearance Requirements.....	5
Mounting Options	6
Mounting the IPC Using the Rear Mounting Holes	7
Mounting the IPC From the Front.....	8
Protective Earth Grounding Requirements.....	9
ELECTRICAL INSTALLATION.....	10
Pilot Power	10
AC Input Circuit	11
Plug Selection	11
Cable / Conductor Selection	11
Circuit Breaker and Contactor Selection	12
AC Input Harness.....	13
Drive Power Request (DPR) Signal	14
IPC DC Output Power-Up.....	15
IPC DC Output Power-Down	15
Removing DC Output Power	15
Emergency Power-Down (E-Stop)	16
P5 - DC Output	16
P6 - Expansion Connector	16
APPENDIX A: IPC CABLE DRAWINGS	17
DC Output Cable	17
AC Input Cable: 90-250VAC Single Phase/Three Phase	18
AC Input Cable: 5-Wire, Three Phase.....	19
APPENDIX B: IPC CONNECTOR REFERENCE	20
APPENDIX C: LED STATUS CODES	22

INTRODUCTION

WHAT IS THE AMAZON INTELLIGENT POWER CENTER?

At its core, the Amazon Intelligent Power Center (IPC) is a DSP-managed power supply that delivers clean, stout power to 300 volt DC-powered servo drives. But the Amazon IPC is more than just a power supply.

Amazon IPC Standard Features:

- Three AC line options
 - Single-phase, 90-250VAC (208-240 VAC nominal)
 - Three-phase, 90-250VAC (208-240 VAC nominal)
 - 5-wire (155-415VAC) three-phase (360-415VAC nominal)
- Power regeneration management
- Input contactor control
- Over-voltage and over-current protection
- Automatic bus power dump
- Active brake clamping

THE BOTTOM LINE

The Amazon IPC is a complete power solution. It outputs high quality DC power, eliminates expensive, bulky transformers, and provides the power management structure that you, as a machine builder, would otherwise have to design, build, and install yourself. What's more, the Amazon IPC provides these features in a compact, well-engineered unit for about the same cost as the "pile of parts" it replaces.

SAFETY

GENERAL PRECAUTIONARY STATEMENT

Always follow appropriate safety precautions when installing and applying a power supply. Equipment should be designed and utilized to prevent personnel from coming into contact with moving parts and electrical contacts that could potentially cause injury or death. Read all cautions, warnings and notes before attempting to operate or service power supplies and motion control devices. Follow all applicable codes and standards when using this equipment. Failure to apply this equipment as described may impair or neutralize protections built into the product.

SYMBOLS USED IN THIS MANUAL

The following symbols and conventions are used on the equipment and in this manual. Please read all equipment labels and manuals before attempting to use Amazon IPC power supplies.

Caution, risk of danger



Identifies information about practices or circumstances that can lead to equipment damage, personal injury, or loss of life.

Shock hazard



Identifies presence of hazardous electrical voltages and currents.

Protective earth terminal



Indicates points that must be connected to a reliable earth system for safety compliance. Protective earth connections should never be omitted.



Earth ground terminal



Frame or chassis terminal (shield)



Direct current

Note



Identifies information that is critical for successful application and understanding of the product.

Tip



Identifies additional information that may be helpful in supporting certain applications.

SYSTEM OVERVIEW (MODELS LX AND FX)

The figure below shows an Amazon IPC powering two Eclipse DC servo drives from a 3-phase, 210VAC source. Note: the IPC can also operate from single phase 90-250VAC, and 5-wire 155-415VAC (European power). Switching from one type of AC line input to another involves changing the AC input harness and a few external components¹.

Amazon IPC nominal AC input voltages:

- 208-240VAC for single and 3-phase (US)
- 360-415 VAC for 3-phase 5-wire (European)

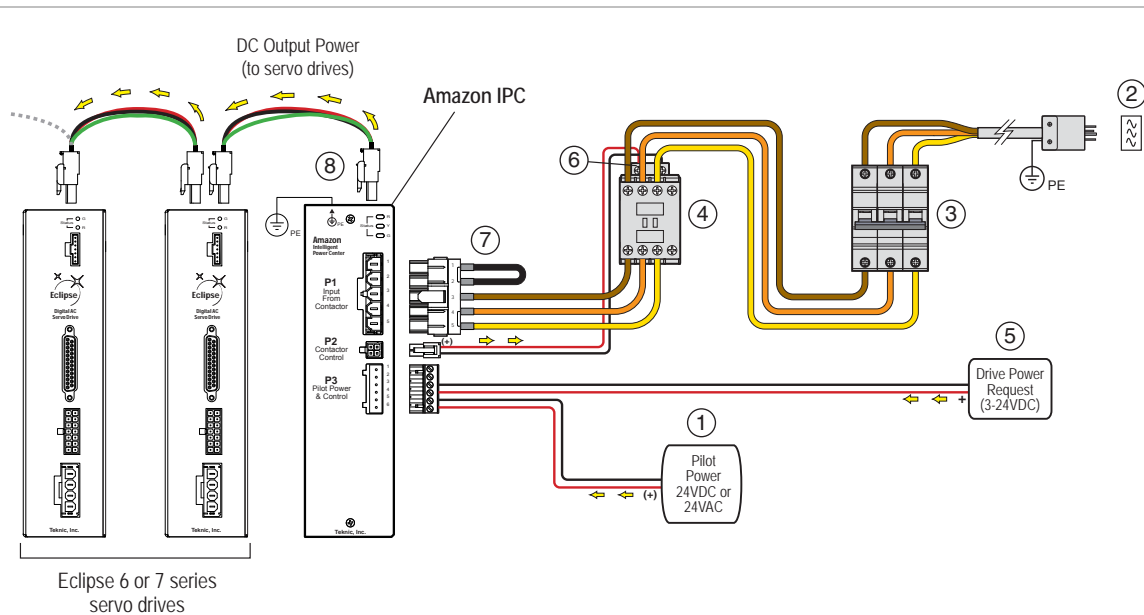

Amazon IPC system (three-phase, 210VAC shown)

AMAZON IPC OPERATION

The following is an abbreviated description of operation for the Amazon IPC system pictured above. Greater detail on individual components, connectors, and wiring is provided throughout the manual and in the appendices.

To begin with, Pilot Power [1] must be applied at connector P3. Pilot Power serves two purposes in the IPC: 1) it supplies voltage to the DSP and internal logic circuits and 2) it is used to energize the contactor coil. The IPC cannot power up or operate without Pilot Power.

Line power from the AC source [2] passes through the circuit breaker [3] to the contactor [4].

To power up the DC bus, the Drive Power Request (DPR) signal [5] must be asserted. The 3-24VDC DPR signal can come from an unused controller output, or it can be a simple power supply and rocker switch.

¹ This may include the contactor, breaker, cable, and/or plug, depending on your AC line power.

When the DPR signal is asserted, the IPC connects 24VDC or 24VAC Pilot Power² to the contactor coil [6] through P2.

When the contactor coil is energized, main AC voltage passes through the contactor and AC input cable [7] into the IPC at connector P1. The IPC then begins its main DC output power-up cycle. A soft start circuit prevents nuisance circuit breaker trips during this phase.

The IPC then runs a self diagnostic. If no faults are detected, The IPC releases full output power to the DC output connector P5 [8]. If a fault is detected, the IPC performs a safety shutdown.³ The power-up cycle takes 2 seconds to complete (after the DPR signal is asserted).

From P5, DC power is distributed to any connected servo drives. Teknic Eclipse 6xx and 7xx servo drives require a single, inexpensive cable to carry DC power from drive to drive. See Appendix A for cable drawings.



Shock Hazard: Hazardous voltage is present at P5 and P6 immediately after the contactor closes. Treat these contacts and circuits as hazardous at all times.

² The type of voltage (24VAC or 24VDC) depends on Pilot Power and contactor selected.

³ Under certain rare circumstances (e.g. the main contacts weld shut) hazardous energy could remain on the DC bus despite the IPC's attempt to remove power.

MECHANICAL INSTALLATION

Follow these important guidelines to ensure that your Amazon IPC is mounted correctly. This section covers the following topics:

- Mounting orientation and clearance requirements
- Mounting options, hardware, and tools
- Grounding requirements

MOUNTING ORIENTATION AND CLEARANCE REQUIREMENTS

- **Mounting Orientation** - Mount the Amazon IPC vertically against a metal surface to achieve maximum power output and component life. Never mount the IPC upside down. Inverting the device will reduce or eliminate the internal fan's cooling capacity, and may lead to thermal problems.

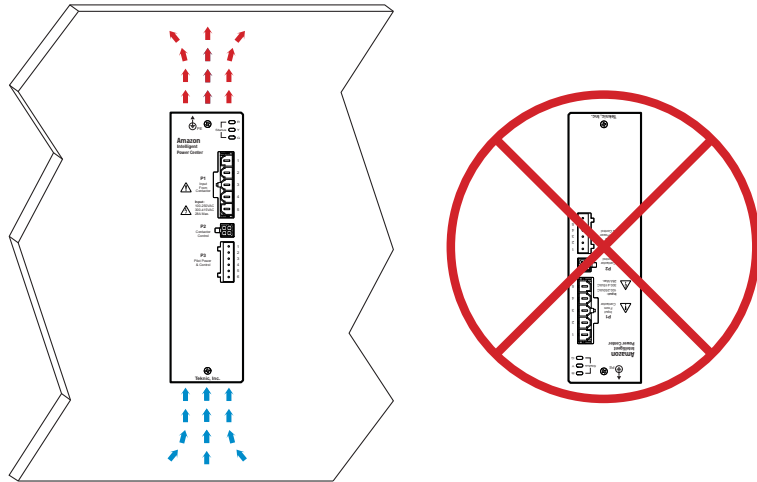

Approved mounting orientation for Amazon IPC

- **Mounting the Amazon IPC near servo drives** - If the IPC is to be mounted in an enclosure with servo drives, mount the units as shown in the figure on next page. It is also acceptable to mount the IPC above the servo drives.



Note: Never mount the IPC below servo drives or other heat sensitive devices. This can force hot air into the servo drive enclosure which can reduce drive output and cause thermal shutdowns.

- **Minimum spacing and clearance guidelines** - Follow the minimum spacing guidelines (see figure on next page) to ensure proper airflow.



Note: Failure to follow minimum spacing requirements may lead to reduced output capacity and thermal failure.

- **Environmental considerations** – The Amazon IPC is rated for indoor use in a pollution degree 2 or cleaner environment. The IPC is rated for operation in ambient temperatures between 0°-40°C and at relative humidity of 0-95% (non-condensing).

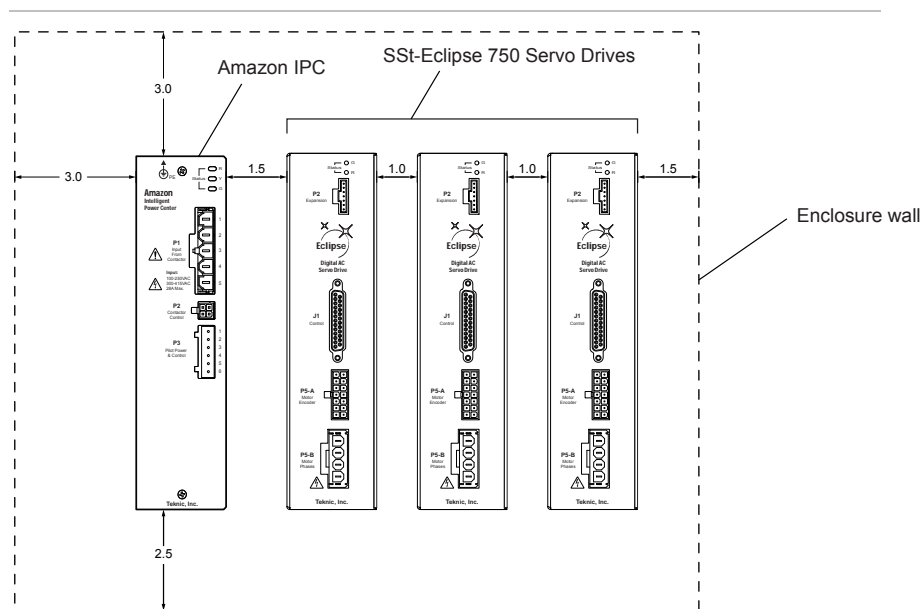

Minimum spacing requirements for Amazon IPC with servo drives

MOUNTING OPTIONS

There are two approved methods for mounting the Amazon IPC:

1. **Rear mounting holes** - Fasten the Amazon IPC to a panel or cabinet from behind using two (2) size #10-32 screws. Limit screw length to 0.5 inch maximum penetration into the chassis. Refer to the mounting diagrams for other important details.
2. **Mounting flanges** - Mount The Amazon IPC from the front using the mounting flange slots on the sheet metal case. Refer to the mounting diagrams for important details.

Detailed Mounting diagrams for these two methods appear on the following pages. Carefully read the section on grounding before installing this product.

Note: The drive mounting surface should be a clean, uncoated metal surface. An unpainted, uncoated cabinet or backplane is ideal. Mounting screws should be an electrically conductive material such as stainless steel. Avoid anodized mounting screws. If the mounting surface is painted, a star washer or external tooth lock washer may provide sufficient electrical continuity.

Note: The machine's protective earth connection must connect to the mounting surface for the IPC, servo drives, and motors.



Caution: The power supply and drive enclosure should be designed to prevent an end user from accessing the IPC and Eclipse drives when hazardous power is applied.

MOUNTING THE IPC USING THE REAR MOUNTING HOLES

Install your Amazon IPC into a panel or cabinet using the two rear mounting holes as shown below. **Important:** limit the screw length so that no more than 1/2" of the screw extends into the Amazon IPC case.

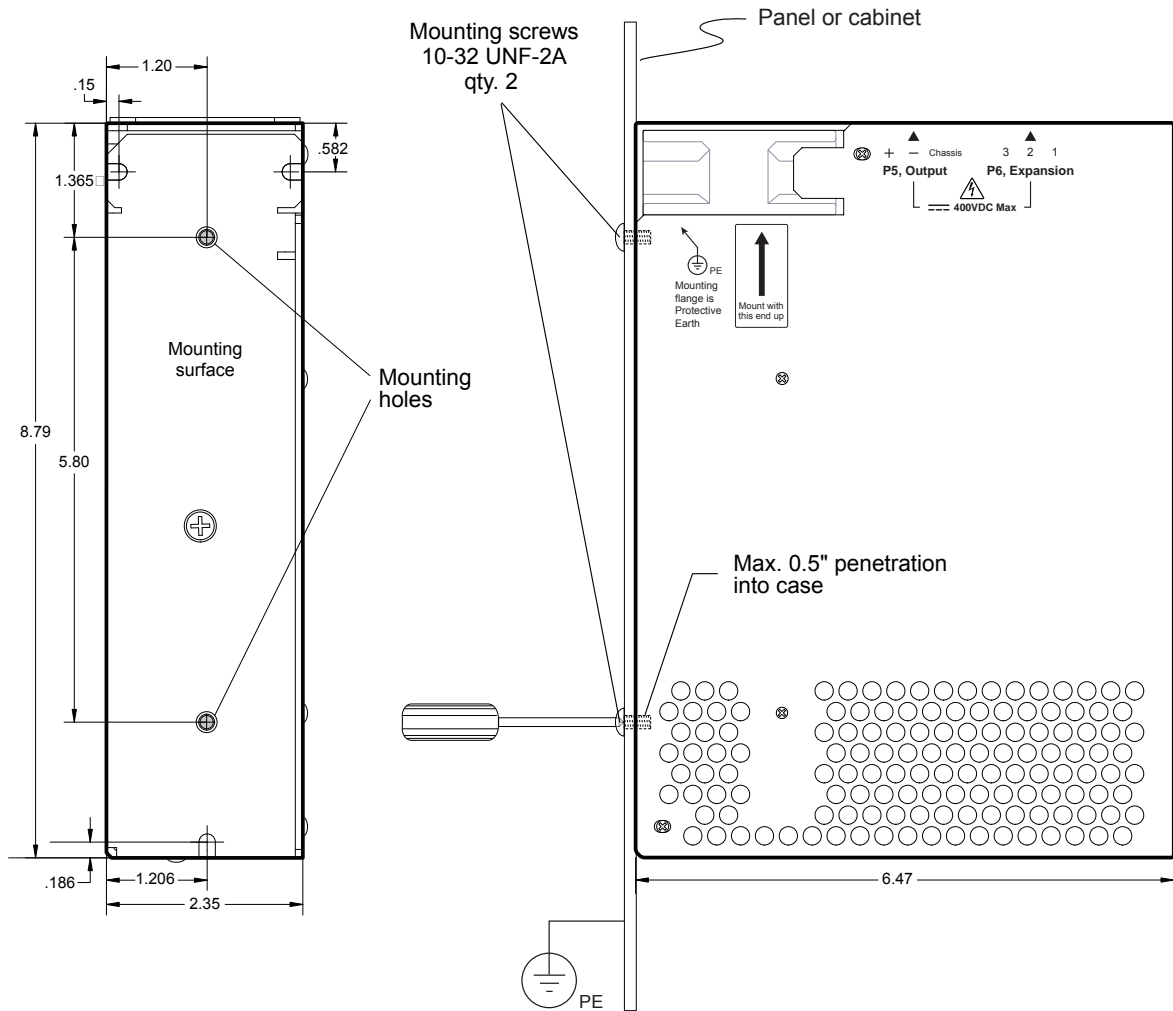

Amazon IPC panel or cabinet mounting using rear mounting method

MOUNTING THE IPC FROM THE FRONT

The Amazon IPC has three mounting flange slots cut into the chassis to facilitate front access mounting. Use three #10-32 socket head cap screws and a 5/32" ball nose Allen driver.



Note: When front-mounting the Amazon IPC, be sure to leave adequate space around the unit for tool clearance. A long, ball nose Allen driver is required as the mounting flanges are located in recessed positions on the chassis (to minimize the IPC's footprint). Follow the minimum spacing guidelines (see figure on page 5) to ensure adequate tool clearance.

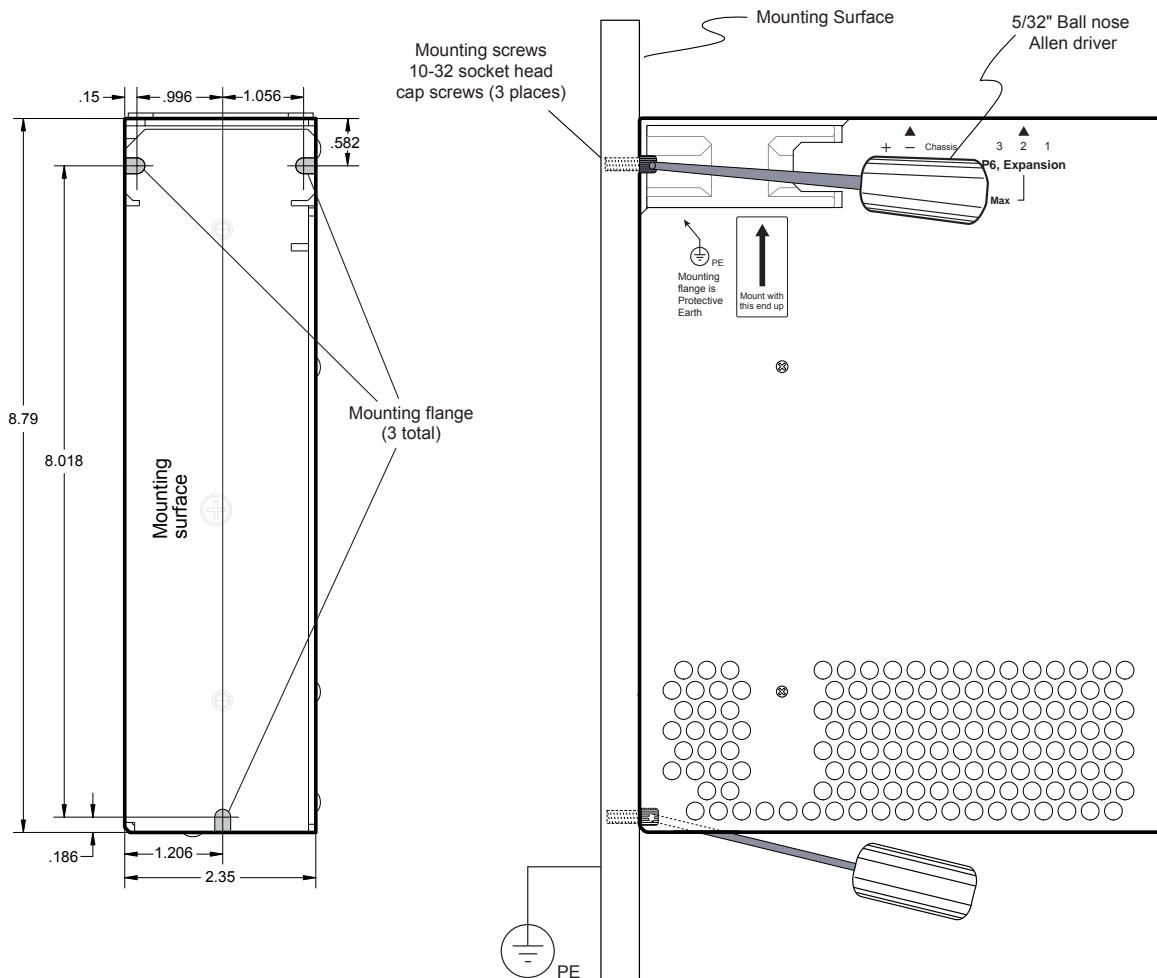

Mounting the Amazon IPC using the front mounting method

PROTECTIVE EARTH GROUNDING REQUIREMENTS

For safe, reliable operation, your Amazon IPC *must* be bonded to Protective Earth Ground. The sections below explain IPC Protective Earth grounding requirements.



Note: Failure to properly ground the IPC will result in operational problems.

If the panel or cabinet is properly bonded to Protective Earth Ground, the IPC mounting screw holes (or flanges for front mounted units) will connect the IPC chassis to Protective Earth. Be sure to use uncoated screws and clean threads (no paint or anodize) when securing the IPC to the mounting panel.

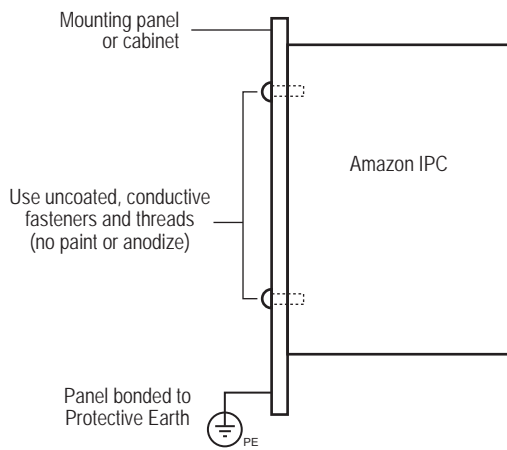

Grounding when panel/cabinet is bonded to Protective Earth

If the panel or cabinet is *not* bonded to Protective Earth Ground, use the #10-32 threaded insert located on the top surface of the Amazon IPC to connect the unit to PE ground. Refer to the figure below for important details.

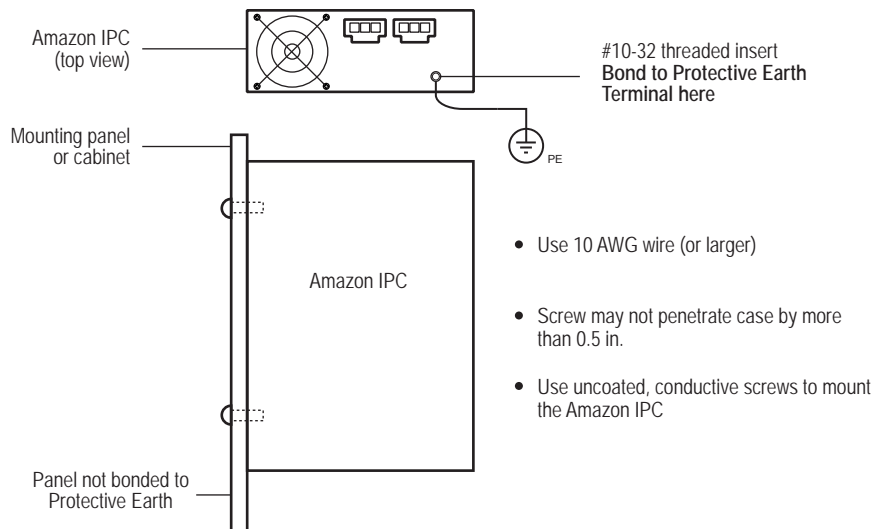

Grounding when panel/cabinet is not bonded to Protective Earth

ELECTRICAL INSTALLATION

This section addresses the Amazon IPC electrical setup for models LX and FX in both the 2500W and 6000W power classes. Topics discussed in the section include:

- Pilot Power
- AC Input Circuit
- Drive Power Request (DPR) Signal
- DC Output

PILOT POWER

Pilot Power must be present at connector P3 before the Amazon IPC can operate. Pilot Power is a user-supplied 24VDC or 24VAC @ 1 amp power supply that serves two purposes in the IPC:

- 1) It powers the IPC's onboard logic (DSP and other logic devices).
- 2) It supplies the voltage required to energize the contactor coil.

The figure below illustrates the dual functionality of Pilot Power in the Amazon IPC.

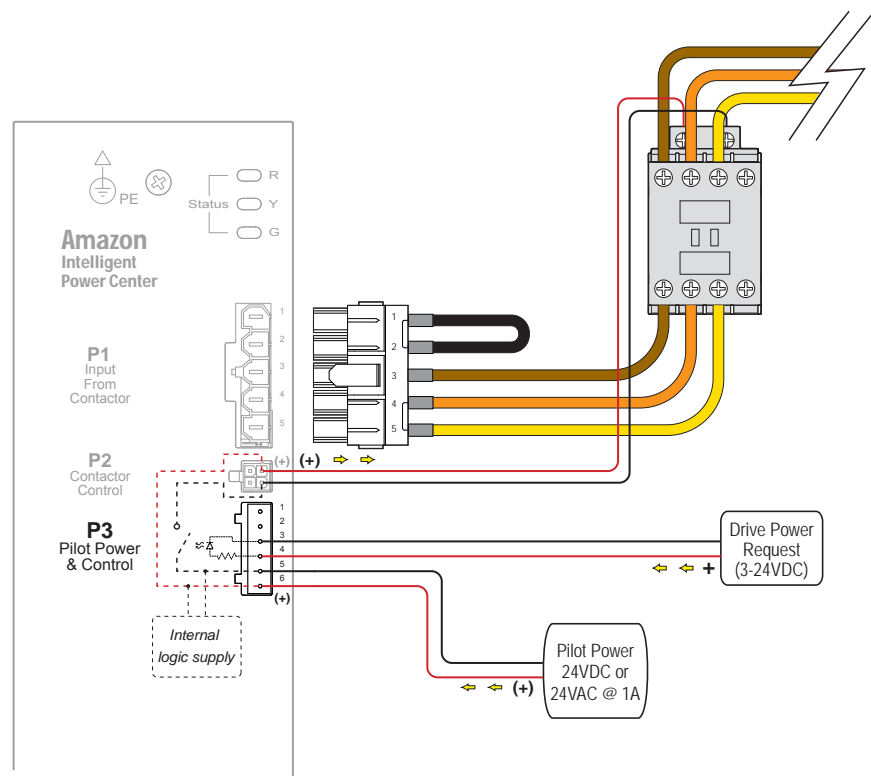

Pilot Power circuit



Note: The Pilot Power supply type (AC or DC) must be consistent with the contactor type, i.e. a 24VDC Pilot Power supply must be paired with a 24VDC contactor, and a 24VAC Pilot Power supply requires a contactor with a 24VAC coil.



Note: The approved DC contactors (see table 2) are the non-polarized type (i.e. you can reverse the leads and the unit will still work). If you select a polarity sensitive DC contactor, follow the polarity markings shown in the previous figure and in Appendix B.

AC INPUT CIRCUIT

For convenience and flexibility, The Amazon IPC can accept AC line input from the following sources:

- Single phase, 90-250VAC
- Three phase, 90-250VAC
- 5-wire (155-415VAC)

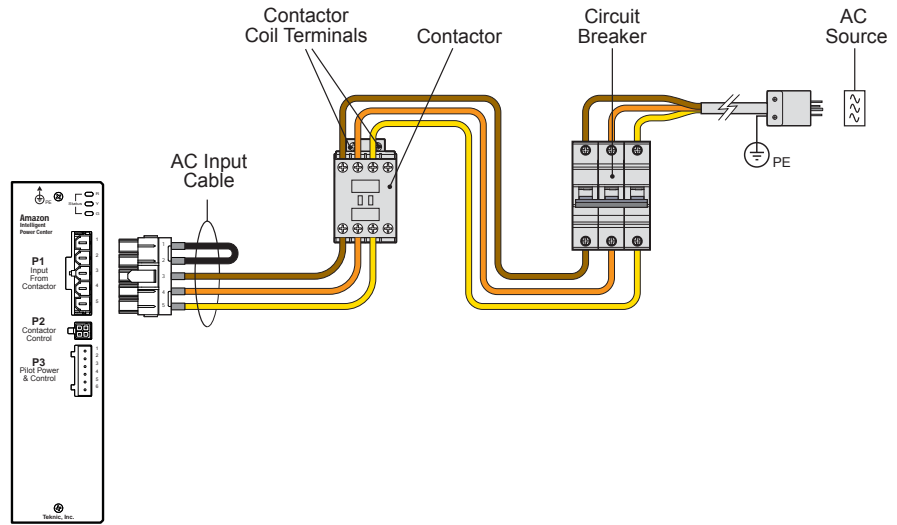

AC input path (Three phase configuration shown)

PLUG SELECTION

This is a user-defined component. Select a plug appropriate for the power requirements of your project and local electrical codes.

CABLE / CONDUCTOR SELECTION

The recommended cable is rated for 600 volts minimum with stranded 10 AWG conductors.

CIRCUIT BREAKER AND CONTACTOR SELECTION

Refer to the Table 1 for circuit breaker and contactor selection data. Select a circuit breaker with a tripping delay characteristic similar to that shown in the figure below.

	IPC-75	IPC-25	Units
Power Out nominal	6000	2500	Watts
Voltage Out nominal	300	300	Volts DC
DC continuous current	20	8.33	Amps DC
AC input circuit breaker	25	12	Amps AC

Table 1 - Input/output power, voltage, and current

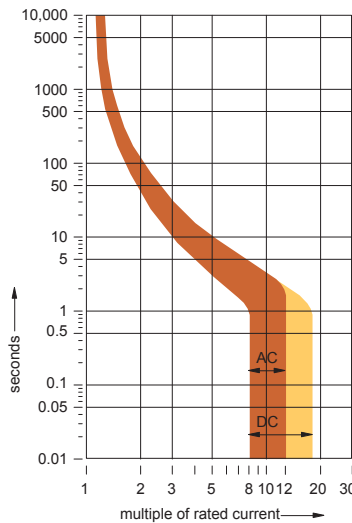

Graph of typical circuit breaker trip delay characteristic

Teknic has tested and approved the following contactors for use with the Amazon IPC:

	IPC-75	IPC-25
Manufacturer	Sprecher & Schuh	Sprecher & Schuh
Contact Configuration	3 NO + 1 NC	3 NO + 1 NC
Part Number (24VDC coil)	CA7-23C-01-24D	CA7-9C-01-24D
Part Number (24VAC coil)	CA7-23-01-24Z	CA7-9-01-24Z

Table 2 - Recommended contactors



Note: The contactor coil power output is protected by a self-resetting over-current device rated at 0.75A continuous.

Note for 5-wire (155-415VAC) users: Electrical code in some localities requires that contactors used in 5-wire power systems must break the neutral wire. In this case, the contactor would require three normally open contacts + neutral.

AC INPUT HARNESS

The **AC Input harness** is comprised of two cables 1) the **AC Input cable**, which runs from the contactor output to the AC input connector P1, and 2) the **Contactor Control cable** which runs from the contactor coil to connector P2.

Teknic manufactures three AC Input harnesses (see figure below). Select the harness appropriate for your AC power source. Complete drawings for these harnesses appear in the appendix.

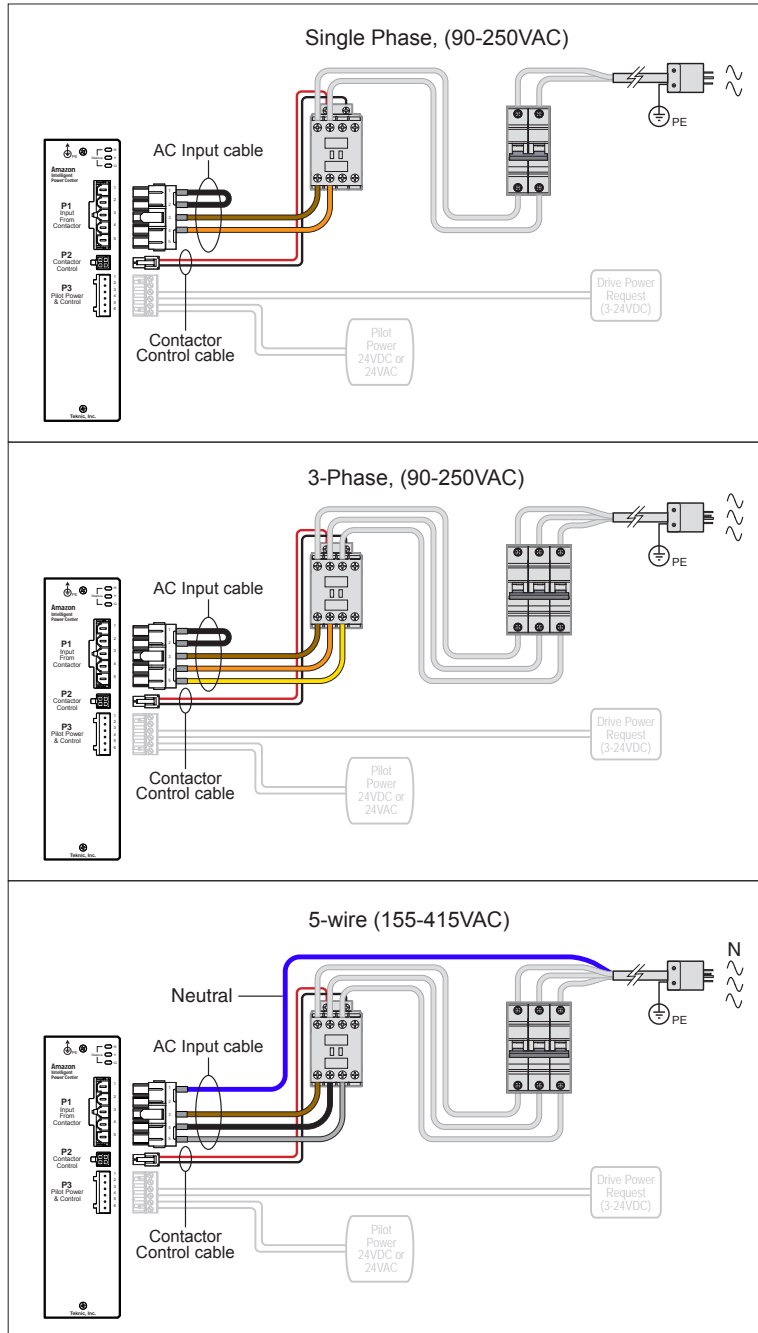

AC Input harness options



Shock Hazard: Never connect or disconnect servo drives from the Amazon IPC DC output bus when power is applied. Doing so may result in electric shock to the operator and electrical arcing that may damage components connected to the system.

DRIVE POWER REQUEST (DPR) SIGNAL

The **Drive Power Request (DPR)** signal acts as the Amazon IPC's DC output on/off switch. The user provides this 3-24VDC signal to pins 3 and 4 on connector P3.

The Drive Power Request signal can originate from a controller output, or it can be something more manual, such as a DC power supply/rocker switch combination. Refer to Table 3 for Drive Power Request voltage and current requirements.

Drive Power Request Voltage	Min. Current
3VDC	2mA
5VDC	4mA
12VDC	12mA
24VDC	24mA

Table 3 - Drive Power Request voltage and current requirements

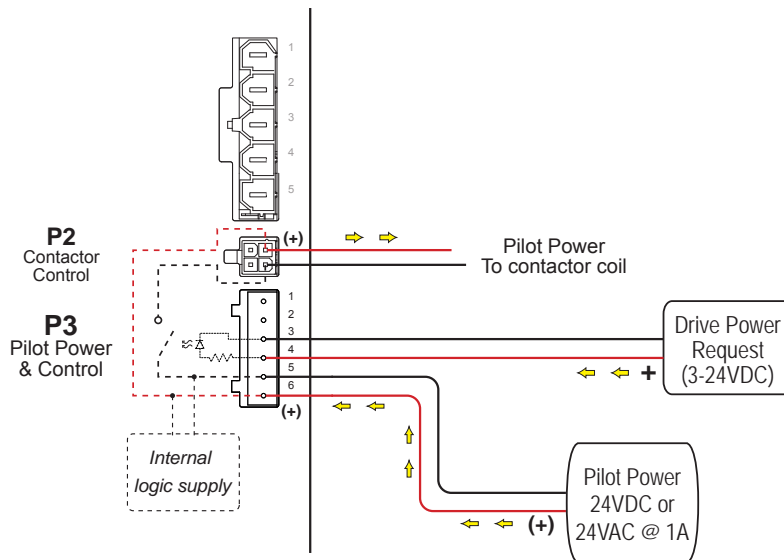

Drive Power Request and Pilot Power operation

IPC DC OUTPUT POWER-UP

The DPR signal operates as described by the timing diagram and steps listed below.

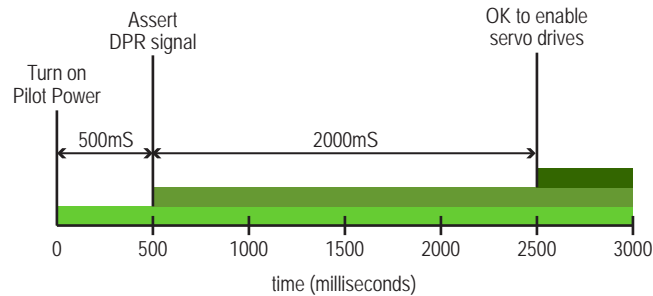

Power-up timing (minimum timing between events)

1. Pilot Power must be applied a minimum of 500mS before the DPR signal is asserted.
2. The DPR signal is asserted by the operator. The DPR voltage turns on an optocoupler LED within the IPC (see figure above).
3. The optocoupler LED provides the Drive Power Request to the DSP. The DSP then checks the status of the IPC and the machine. If the status is OK, the DSP turns on an internal relay (the relay associated with the Pilot Power circuit) providing an internal path for Pilot Power from P3 to P2.
4. Pilot Power (now present at P2) energizes the contactor coil.
5. The contactor closes and main AC input power is released to P1. This initiates the main DC Output power-up cycle.
6. If no faults are detected by the IPC, full DC power is released to P5 (the DC Output connector) 2000mS after the DPR signal is asserted.
7. At this point, the DC bus is fully powered and any connected servo drives can be enabled at will.



Note: Pilot Power must be present at P3 for at least 500mS before the Drive Power Request signal is asserted to ensure that the Amazon's DSP is fully booted.



Shock Hazard: Asserting the Drive Power Request signal, when Pilot Power is on and AC Input power is present at the contactor input, will energize the contactor coil, sending hazardous DC voltage to P5 (and any connected servo drives).

IPC DC OUTPUT POWER-DOWN

REMOVING DC OUTPUT POWER

To remove DC output voltage from the IPC (and all connected servo drives) turn off the DPR signal. This initiates the DC output power-down cycle causing the main contactor to open and discharge all stored DC bus energy to an internal dump resistor.

Under normal operating conditions the IPC and servo drives are fully discharged and safe to handle 5 seconds after the DPR signal is removed.

Do not remove pilot power until the DC bus dump is complete (i.e. wait 5 second at least).

EMERGENCY POWER-DOWN (E-STOP)

During an E-stop event, main power to the IPC is immediately interrupted. It is advisable to design any E-stop implementation such that it automatically turns off the DPR signal as well.



Note: In order to power-up the IPC after an E-stop or other power interruption, you must de-assert (turn off) the DPR signal and follow the power-up sequence as described earlier in this section. If the DPR signal is asserted before (or at the same time as) the Pilot Power voltage, *the IPC will not power up*. The unit will immediately go into a self-protection shutdown mode. Follow the proper power-up sequence to clear the shutdown.

P5 - DC OUTPUT

P5 is the DC output connector. When AC power is available at P1 and the contactor coil is energized, the nominal DC output voltage will be present on this connector. See the appendix for a detailed DC output cable drawing. The DC output connector (P5) cannot be accessible when the Amazon IPC is powered on.

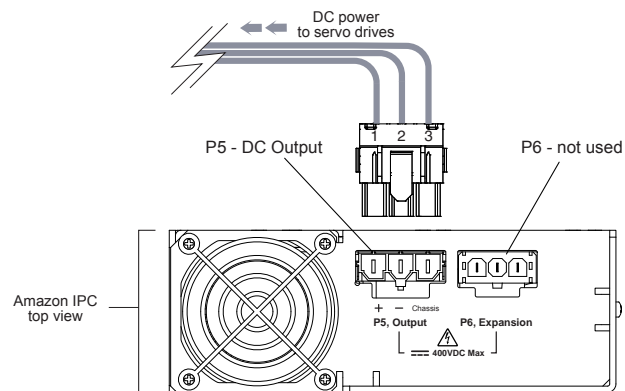

DC output connector P5



Note: The “rigid test finger”—a test tool recognized by both UL and EN-61010-1—can touch the electrical contacts when P5 is not populated with a mating connector. This is also true of the motor power connectors on the E6xx/7xx servo drives. This does not present a hazard or compliance issue provided the final machine design prevents operator access to the IPC and servo drives when power is applied.

P6 - EXPANSION CONNECTOR

Expansion connector P6 is reserved for future use; make no connection to it.



Shock Hazard: Hazardous voltage is present on P5 and P6 whenever DC output power is on.

APPENDIX A: IPC CABLE DRAWINGS

DC OUTPUT CABLE

WIRE ENTRY VIEW

1 RED
2 BLK
3 GRN

WIRE ENTRY VIEW

1 RED
2 BLK
3 GRN

J1, J2 ASSIGNMENTS

COLOR	PIN	SIGNAL
RED	1	V+
BLACK	2	V-
GRN	3	CHASSIS

BREAK OFF AND ASSEMBLE AS SHOWN AFTER INSTALLING TERMINALS

POSITION HEATSHRINK AS SHOWN AND SHRINK BEFORE INSTALLING TERMINALS

CONFIDENTIAL

Teknic, Incorporated
 Rochester, NY 14634 USA
This document and related electronic files are the sole property of Teknic, Incorporated and contain proprietary information. The use, distribution, or reproduction of this document without written permission is prohibited.

All dimensions are in inches unless otherwise noted.
 Third-Angle Projection

Interpret Geometric Tolerances per ANSI/ASME Y14.5M (1994).
 Underscored dimensions are basic.

BILL OF MATERIALS

ITEM	PART NUMBER	DESCRIPTION	QTY
1	ALPHA/3080-3	WIRE, 12 AWG, 600V, RED	1
2	ALPHA/3080-2	WIRE, 12 AWG, 600V, BLK	1
3	ALPHA/3080-4	WIRE, 12 AWG, 600V, GRN	1
4	MOLEX/42816-0312	CONNECTOR, HOUSING	2
5	MOLEX/42815-0011-C	TERMINAL, SOCKET	6
6	PANDUIT/PLTM-C	CABLE TIE, 4"	2
7	3M/VPP-876	TUBING, Ø1/4" BLK	6

Drawn By: drafter
 Filename: dc7_12g_8
 ECOO #: 0
 ECOO Description: prototype

Drawn Date: 11/8/2007
 Saved Date: 1/30/2008

REVISIONS		DATE
REV	DESCRIPTION	DATE
A	INITIAL RELEASE	1/30/2008

TITLE: DC BUS CABLE, AMAZON/ECLIPSE **DWG. NO./REV: DC7-12G-8/A**

1 of 1 Pages

AC INPUT CABLE: 90-250VAC SINGLE PHASE/THREE PHASE

Notes:

1. For items 6, 13 (Wires) an alternate manufacturer and/or part number may be used so long as all attributes listed in the description are met or exceeded.

Notes

J1 Assignments	J2 Assignments
1 BLK	1 BLK
2 BLK	2 BLK
3 BRN	3 BRN
4 ORN	4 ORN
5 YEL	5 YEL

J2 Assignments	J1 Assignments
1 RED	1 SIGNAL
2 BRK	2 COIL A
3 BRN	3 COIL B
4 W/O	4 AUX

ITEM NO.	PART NUMBER	DESCRIPTION	QTY.
J1	MOLEX/2816-0512	CONNECTOR HOUSING	1
J1-A	MOLEX/2815-0011	CRIMP TERMINAL, FEMALE	5
J2	MOLEX/39-01-2045	RECEPTACLE HOUSING	1
J2-A	MOLEX/39-00-0038	CRIMP TERMINAL, FEMALE	4
5	3M/VF-P976	TUBING 1/4" BLK	5
6	GENERAL CABLE/CAROL/CC2107A-01	WIRE 10AWG, 600V, 105°C, PVC, BK, UL STYLE 1015, STRANDED 105/750 STRANDING	1
7	GENERAL CABLE/CAROL/CC2107A-0B	WIRE 10AWG, 600V, 105°C, PVC, BRN, UL STYLE 1015, STRANDED 105/750 STRANDING	1
8	GENERAL CABLE/CAROL/CC2107A-04	WIRE 10AWG, 600V, 105°C, PVC, RED, UL STYLE 1015, STRANDED 105/750 STRANDING	1
9	GENERAL CABLE/CAROL/CC2107A-0B	WIRE 10AWG, 600V, 105°C, PVC, YEL, UL STYLE 1015, STRANDED 105/750 STRANDING	1
10	GENERAL CABLE/CAROL/CC2107A-0B	WIRE 24AWG, 300V, 90°C, PVC, RED, UL STYLE 1015, STRANDED 105/750 STRANDING	1
11	GENERAL CABLE/CAROL/CC2107A-01	WIRE 24AWG, 300V, 90°C, PVC, BRN, UL STYLE 1015, STRANDED 105/750 STRANDING	1
12	GENERAL CABLE/CAROL/CC2107A-02	WIRE 24AWG, 300V, 90°C, PVC, BK, UL STYLE 1015, STRANDED 105/750 STRANDING	1
13	GENERAL CABLE/CAROL/CC2107A-19	WIRE 24AWG, 300V, 90°C, PVC, WHT, UL STYLE 1015, STRANDED 105/750 STRANDING	1
14	PANDUIT/RT11MC	CABLE TIE #	1

TEKnic, Incorporated
 Rochester, NY 14624, USA
 The customer and related device files are the sole property of the customer. This drawing is the property of Teknic, Inc. and is confidential. Any reproduction or use without written permission is prohibited.

All dimensions are in inches unless otherwise noted.
 Unrounded dimensions are basic.

ECO # ECO Description

0 prototype

Drawn By: acs10/24
 Date: 10/24

Checked By: 11/08
 Date: 10/20/08

TITLE: 3 wire Harness, amazon

DWG. NO./REV: AC3-10G-24/A

1 of 1 Pages

RESPONSE

DESCRIPTION: INFRA RELEASE

DATE: 10/1/2008

AC Input Cable for 100-250VAC Single Phase or Three Phase Systems

AC INPUT CABLE: 5-WIRE, THREE PHASE

BREAK OFF AND ASSEMBLY AS SHOWN
AFTER INSTALLING TERMINALS

POSITION HERE/SHRINK AS SHOWN
AND THEN CRIMP BEFORE INSTALLING
TERMINALS

J1 Assignments	
PN	SIGNAL
COLOR	VC-
1	BLU
2	BRN
3	BLK
4	GRY
5	PHI

J2 Assignments	
PN	SIGNAL
COLOR	COL
1	RED
2	WHI
3	BLK
4	BLK

REV	DESCRIPTION	DATE
A	INITIAL RELEASE	1/25/2008

ITEM NO.	PART NUMBER	DESCRIPTION	QTY.
J1	MOLEX/2816-0512	CONNECTION HOUSING	1
J1-A	MOLEX/2815-0011	CRIMP TERMINAL, FEMALE	4
J2	MOLEX/39-01-2045	RECEPTACLE HOUSING	1
J2-A	MOLEX/39-00-0038	CRIMP TERMINAL, FEMALE	4
5	3M/VIP-878	TUBING 1/4" BK	4
6	PANDUIT/ETIM4-C	CABLE TIE 4"	1
7	GENERAL CABLE/CANOL/C2107A.07	WIRE 10AWG, 600V, 105°C, PVC, BLU, UL STYLE 1015, STRANDED (105/50 STRANDINGS)	1
8	GENERAL CABLE/CANOL/C2107A.08	WIRE 10AWG, 600V, 105°C, PVC, GRN, UL STYLE 1015, STRANDED (105/50 STRANDINGS)	1
9	GENERAL CABLE/CANOL/C2107A.01	WIRE 10AWG, 600V, 105°C, PVC, BK, UL STYLE 1015, STRANDED (105/50 STRANDINGS)	1
10	GENERAL CABLE/CANOL/C2107A.10	WIRE 10AWG, 600V, 105°C, PVC, GRN, UL STYLE 1015, STRANDED (105/50 STRANDINGS)	1
11	GENERAL CABLE/CANOL/C2015A.03	WIRE 24AWG, 300V, 80°C, PVC, RED, UL STYLE 1007/1549, STRANDED	1
12	GENERAL CABLE/CANOL/C2015A.01	WIRE 24AWG, 300V, 80°C, PVC, BLK, UL STYLE 1007/1549, STRANDED	1
13	GENERAL CABLE/CANOL/C2015A.02	WIRE 24AWG, 300V, 80°C, PVC, WHI, UL STYLE 1007/1549, STRANDED	1
14	GENERAL CABLE/CANOL/C2015A.19	WIRE 24AWG, 300V, 80°C, PVC, VIO, UL STYLE 1007/1549, STRANDED	1

TECHNICAL SPECIFICATIONS:

- Rated Voltage: 380-415VAC
- Rated Current: 10A
- Rated Power: 3700W
- Rated Frequency: 50/60Hz
- Rated Temperature: 105°C
- Rated Humidity: 95% RH
- Rated Vibration: 10g
- Rated Shock: 10g
- Rated Lifetime: 100,000 hours

REVISIONS:

1 of 1 pages

AMAZON 5 WIRE HARNESS

amazon 5 wire harness

ac5-10g-24/A

DWG. NO./REV

TEKnic, Incorporated
 Rockledge, NY 14534 USA

All dimensions are in inches unless otherwise noted.

Interpret Geometric Tolerances per ASME/ANSI Y14.5M (1994).
 Unspecified Dimensions are Basic.

Drawn By: *adbr*
 Fixture: *ad5-10g-24*
 ECO L: 0 ECO Description: *prodtype*

Drawn Date: 1/25/08
 Scaled Date: 1/25/08

AC Input Cable for 5-wire, 380-415VAC three-phase systems

APPENDIX B: IPC CONNECTOR REFERENCE

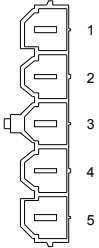
P1 - 3-Phase AC Input	Pin#	Signal	Mate
 <p>Wire entry view</p>	1	Jump to 2	CONNECTOR Molex/42816-0512 CONTACTS Molex/42815-0011-C (10 AWG) CRIMP TOOL Molex/63811-1600 PIN EXTRACTOR Molex/63813-0400
	2	Jump to 1	
	3	AC Phase	
	4	AC Phase	
	5	AC Phase	

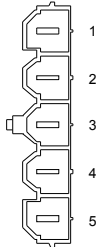
P1 - Single Phase AC Input	Pin#	Signal	Mate
 <p>Wire entry view</p>	1	Jump to 2	CONNECTOR Molex/42816-0512 CONTACTS Molex/42815-0011-C (10 AWG) CRIMP TOOL Molex/63811-1600 PIN EXTRACTOR Molex/63813-0400
	2	Jump to 1	
	3	AC Phase	
	4	AC Phase	
	5	No Connect	

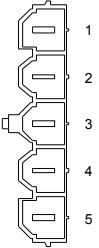
P1 - 5-Wire AC Input	Pin#	Signal	Mate
 <p>Wire entry view</p>	1	Neutral	CONNECTOR Molex/42816-0512 CONTACTS Molex/42815-0011-C (10 AWG) CRIMP TOOL Molex/63811-1600 PIN EXTRACTOR Molex/63813-0400
	2	No Connect	
	3	AC Phase	
	4	AC Phase	
	5	AC Phase	

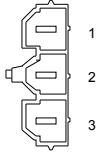
P5 - DC Output	Pin#	Signal	Mate
 <p>Wire entry view</p>	1	V+	CONNECTOR Molex/42816-0312 CONTACTS Molex/42815-0011-C (10 AWG) CRIMP TOOL Molex/63811-600 PIN EXTRACTOR Molex/63813-0400
	2	V-	
	3	Chassis	

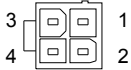
P2 - Contactor Control	Pin#	Signal	Mate
 <p>Wire entry view</p>	1	Coil +(no polarity for AC)	CONNECTOR Molex/39-012040 CONTACTS Molex/39-00-0038 CRIMP TOOL Molex/63811-5000 PIN EXTRACTOR Molex/11-03-0044
	2	Coil- (no polarity for AC)	
	3	No connect	
	4	No connect	

P3 - Pilot Power and Control	Pin#	Signal	Mate
 <p>Wire entry view</p>	1	No connect	CONNECTOR Phoenix/1757051 CONTACTS N/A (screw terminals) CRIMP TOOL N/A PIN EXTRACTOR N/A
	2	No Connect	
	3	Drive Power Request -	
	4	Drive Power Request +	
	5	Pilot Power - (no polarity for AC)	
	6	Pilot Power + (no polarity for AC)	

APPENDIX C: LED STATUS CODES

This table applies to firmware version 1.5.1 and greater.

	Operational Status	Red	Yellow	Green	Description
Operation Modes	No Operation	○	○	○	No Pilot Power (all LEDs off)
	Normal Operation	○	○	●	Pilot Power on, DC bus off, IPC ready for Drive Power Request
		○	○	toggle	IPC powering up - soft start phase
		○	○	flicker	IPC operational - DC bus fully powered
		○	○	toggle	IPC DC bus shutting down, dumping DC bus power
Operational Warning	○	blink (2)	flicker	Thermal warning - board temperature >60°C and <65°C	
Shutdown Modes	Soft Fault Toggle DPR to clear	○	blink (2)	●	Drive Power Request asserted before Pilot Power was on
		○	blink (3)	●	Bus supply failed to reach min voltage threshold on power up
		○	blink (4)	●	Over temperature fault (board temp > 65°C)
		○	blink (5)	●	DPR off-request followed by DPR on-request before IPC fully shut down
		○	blink (6)	●	AC phases disconnected
		○	blink (8)	●	Current calibration error
		○	blink (10)	●	DC output dropped below user-configurable setting (for >1 mS)
	Safety Hazard A dangerous condition exists	●	blink (2)	○	Contactor failed to open - possibly welded
		●	blink (3)	○	AC input voltage high (or 3-pulse wired for 6-pulse)
	User Equipment Fault Cycle Pilot Power to clear	○	blink (2)	○	Over voltage after regen
		○	blink (3)	○	Output current overload
		○	blink (4)	○	Short or reverse polarity at output
		○	blink (5)	○	Contactor failed to close
		○	blink (6)	○	RMS current limit exceeded
	IPC Hardware Fault Hard failure - return to Teknic	●	●	●	Processor failure (all LEDs on solid)
		All blink		Hard failure	

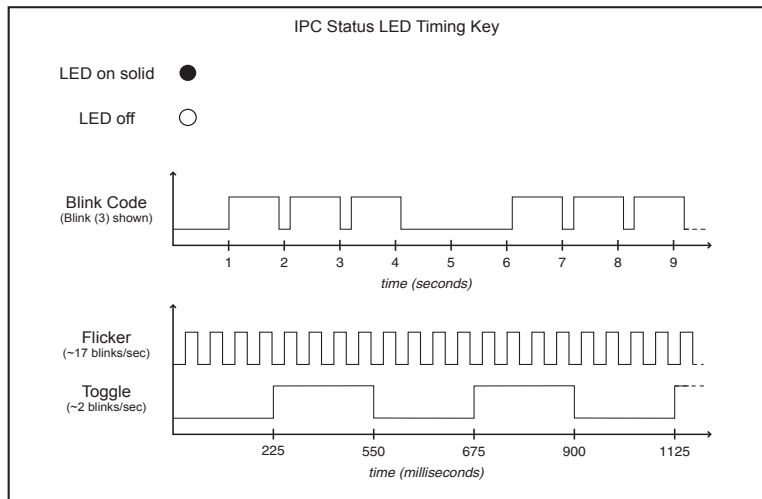

Teknic Incorporated
115 Victor Heights Parkway
Victor, NY 14564

Copyright © 2015 Teknic Inc. All rights reserved